



INSTALLATION GUIDE

www.eurenergroupp.com | more than energy!



INSTALLATION GUIDE

Carefully read through these installation instructions before installing, operating or servicing PV system. Failure to follow these instructions may result in bodily injury or damage to property. Keep these instructions! Working on a PV system (installation, setup, maintenance, repairs) must be carried out by qualified and authorized persons.

DANGER OF DEATH FROM ELECTRIC SHOCK!

Solar modules generate electricity as soon as they are exposed to light. One module on its own is below the safety extra low volt level, but multiple modules connected in series (summing the voltage) or in parallel (summing the current) represent a danger. The following points must be observed when handling the solar modules to avoid the risk of fire, sparking and fatal electric shock.

- Do not insert electrically conducting parts into the plugs or sockets!
- Do not fit solar modules and wiring with wet plugs and sockets!
- Exercise utmost caution when carrying out work on wiring and safety equipment (use insulated tools, insulated gloves, etc.)!
- Do not use damaged modules!
- Do not dismantle modules!
- Do not mark on the rear of the module using sharp objects!
- Exercise utmost caution when working on wiring and the inverter. Be sure carefully to follow manufacture's installation instructions!

DANGER OF DEATH FROM ARCING

Modules generate direct current when light shines on them. An arc may be produced when connections are separated. We therefore recommended covering modules with a lightproof cloth during installation. When breaking a connected string of modules (e.g. when disconnecting the DC line from the inverter under load), a lethally strong arc can occur:

- Never disconnect the solar generator from the inverter while the inverter is connected to the mains grid - remove the fuse from the AC side on the inverter first!
- Ensure cable connections in perfect condition (no splitting, soiling or other contamination)!

UNPACKING THE MODULES AND STORAGE

The utmost care is required when handling the modules. Be careful when unpacking, transporting, and storing the modules:

- Transport modules in an upright position.
- Carry modules with both hands. Do not use the connection socket as a handle.
- Ensure modules do not bow under their own weight.
- Do not place modules on top of each other.
- Do not subject to load, do not stand on them.
- Do not mark using sharp implements.
- Keep all electrical contacts clean and dry.

If it is necessary to store the modules temporarily, a dry, ventilated room should be used.

GENERAL SAFETY INFORMATION

Ensure that the module is used only in applications for which it is suitable (see "Installing the modules"). All work on a PV system (installation, setup, maintenance, repairs) must be carried out only by appropriately qualified and authorized persons. The appropriate DIN standards, construction rules and safety instructions are to be followed for installation.

INSTALLING THE MODULES

When installing the modules, please pay attention to:

KEEPING WITHIN THE MAXIMUM PERMITTED LOAD

The maximum load on the module must not exceed 2.4kN/m². To avoid exceeding the maximum load, site-specific live loads such as wind and snow should taken into account.

ENVIRONMENTAL CONDITIONS

The module is intended for use in temperate climatic conditions. The module is "non-explosion-protected equipment". Hence it must not be installed in the proximity of highly inflammable gases and vapours (e.g. filling stations, gas containers, paint equipment). The module must not be installed near to naked flames or flammable materials. Do not expose modules to concentrated light sources. It must not be immersed in water or constantly exposed to water (e.g. from fountains). If there is exposure to salt (it is recommended that modules are installed at least 500m from the sea) and sulphur (sulphur sources, volcanoes), there is a risk of corrosion.





REQUIREMENTS OF INSTALLATION

Make sure the modules' electrical performances in a system are the same. When connected in series, modules must all have the same amperage. When connected in parallel, the modules must all have the same voltage. Connect the quantity of modules that match the voltage specifications of the devices used in the system. The modules must not be connected together to create a voltage higher than the permitted system voltage. To minimize risk in the event of an indirect lightning strike avoid forming loops when designing the system. Modules must not be fitted as overhead glazing. Ensure that the mounting system can also withstand the anticipated wind and snow loads. Precipitation can run off through small openings on the back side of the module. Make sure that the openings are not masked after mounting.

OPTIMUM ORIENTATION AND TILT

To achieve the maximum annual yield figure out what the optimum orientation and tilt of the PV modules is. If sunlight shines vertical onto the PV modules you have the best conditions to generate maximum power.

AVOID OVERSHADOWING

Even the slightest partial shading (e.g. from dirt deposits) will cause a reduction in yield. A module is considered "shadowfree" if it is unobscured across its entire surface for the whole year and even on the shortest day of the year unobstructed sunlight can reach the module.

RELIABLE VENTILATION

Functioning ventilation prevents the build-up of heat, which would reduce performance.

EARTHING

Although the modules are certified to safety class II, we still recommend earthing them. The earth connection must be made by a qualified electrician.

Option 1:

Connect module frames to each other using cables with cable lugs. Use the hole (M4mm) that are provided for this purpose. To create the conductive connection (frame is anodized), use a serrated washer or a self-tapping screw (3,5mm). The earth connection should be made by a qualified electrician.

Option 2:

Create an electrical connection between the frames and the mounting system, e.g. by using serrated washer, then have the mounting system earthed by a qualified electrician. (See "Mounting" example A).

Do not interrupt or influence the conductive connection

when making daily maintenance. All the crunodes on the conductive connection must be fixed. The fastness does not depend on soldering. The metal containing iron in the conductive connection should be handled by some way, such as anodization, spray-painting, galvanization. Stainless steel does not need to be treated.

MOUNTING

Each module must be securely fastened at a minimum of 4 points. The frame has been stress tested for mounting on the long sides.

EXAMPLE FOR MOUNTING THE PV MODULES TO THE SUBSTRUCTURE:

Example A:

Bolting (earthing is provided by use of the serrated washer).

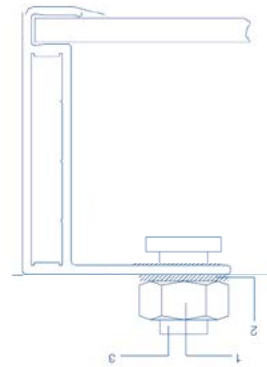

1. Stainless steel M8 nut
2. Stainless steel serrated washer
3. Stainless steel M8 t-head bolt

Example B:

Clamping on (additional earthing required)

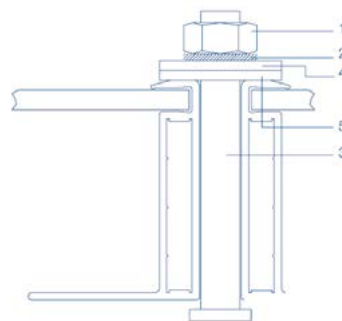

1. Stainless steel M8 nut
2. Stainless steel serrated washer
3. Stainless steel M8 t-head bolt



4. Aluminum clamping plate
5. EPDM washer 2mm

We recommend using a torque wrench for installation. In example B, the tightening torque (using stainless steel M8 bolts) should be around 15-20Nm. Use the existing holes for securing the module and do not drill additional holes (doing so would void the warranty). Use appropriate corrosion-proof fastening materials.

WIRING

For the wiring, pay attention to:

CORRECT WIRING SCHEME

When designing the system, avoid forming loops (to minimize risk in the event of an indirect lighting strike). Check that wiring is correct before starting up the generator. If the measured open circuit voltage (Uoc) and short-circuit current (Isc) differ from the specifications, then there is a wiring fault.

CORRECT CONNECTION OF MULTI-CONTACT (MC) PLUG CONNECTORS

The plug connector has its own polarity. Make sure that the connection is safe and tight. The plug connector should not receive outer stress. Otherwise, it is only used to connect the circuit!

USE OF SUITABLE MATERIALS

Use cable extensions and plugs that are designed for outdoor applications. Ensure that they are in perfect electrical and mechanical condition. Use only cables having one conductor. Select the appropriate cable diameter to minimize voltage drop (to calculate the minimum cable diameter, the fuse, and to calculate controls, multiply the Isc and Uoc by a factor of 1.25).

MAINTENANCE AND CLEANING

Do not change the PV components optionally (diode, junction box, plug connectors). Given a sufficient tilt (at least 15°), it is not generally necessary to clean the modules (rainfall will have a self-cleaning effect). In case of heavy soiling (which will result in output reductions), we recommend cleaning the modules using plenty of water (from a hose) without cleaning agents and using a gentle cleaning implement (a sponge). Dirt must never be scraped or rubbed away when dry, as this will cause microscratched. We recommend that the system be

inspected at regular intervals.

CHECKLISTS:

- All fastenings are tight and secure and free of corrosion.
- All cable connections are secure, tight, clean and free of corrosion.
- Cables are not damaged in any way.
- Checking the earthing resistivity of metals.

MOUNTING INSTRUCTIONS

STANDARD MODULES

For a clear understanding of our modules, please refer to the illustration of a standard module shown below:

1. Grounding holes
2. Junction box
3. Standard mounting holes (long side)
4. Standard mounting holes (short side)
5. (high wind or snow loads)
6. Module frame
7. Cables and connectors

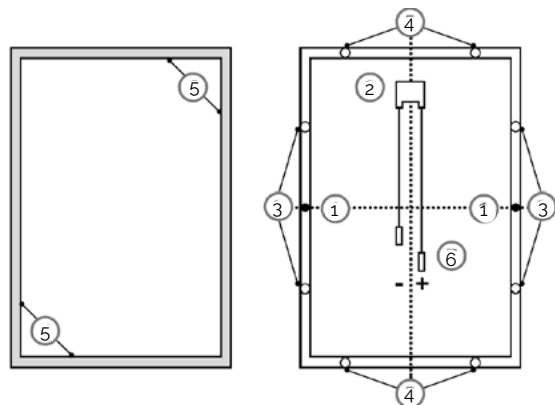

The mounting design must be certified by a registered professional engineer. The mounting design and procedures must comply with local codes and requirements from all relevant authorities.

- Eurener does not provide mounting hardware.
- Standard modules can be mounted onto a support structure using one of several approved methods. One such method is described below.
- Use appropriate corrosion-proof fastening materials.
- All mounting hardware (bolts, spring washers, flat washers, nuts) should be stainless steel.



- Use a torque wrench for installation.
- Do not drill additional holes or modify the module frame. Doing so will void the warranty.
- Standard modules can be installed in either landscape or portrait orientations. Refer to the detailed instructions for further guidance. Please note that in areas with heavy snowfall (>2400 Pa) further countermeasures such as the use of additional support bars should be considered to avoid snow loads damaging the lowest row of modules.
- In cases where an additional support bar is recommended to improve both mechanical stability and long-term module performance, Eurener recommends selecting sufficiently resistant material. Eurener recommends bars with a minimum thickness of 50 mm (1.97 in). The support bar centerline should be positioned within 100 mm (3.94 in) of the side frame centerline (slight shifts may be necessary to access module grounding holes).

MOUNTING METHOD: BOLTING

- The mounting method has been qualified by Eurener - European Energy World SL. Modules should be bolted to support structures through the mounting holes in the rear frame flanges only.
- Each module must be securely fastened at a minimum of 4 points on two opposite sides. M6X1 Grade8.8 bolt and nut are used for bolting method. Tightening torques should be within 6-12 Nm (4.4-8.9 ft-lbs) and (17-23) Nm (12.5-17.0 ft-lbs) respectively for M6 and M8 coarse thread bolts, depending on bolt class. In areas with heavy wind loads, additional mounting points should be used. The system designer and the installer are responsible for calculating the load and ensuring that the support structure meets the requirements.
- Design load and safety factors will be determined by the racking suppliers or professional engineers.
- For detailed information, please follow local structural code or contact your professional structural engineer.

Mounting method: Bolting

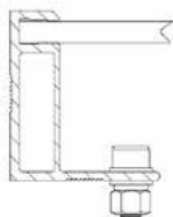

Modules should be bolted at the following hole locations depending on the configuration and load:

APPROVED BOLTING METHODS

Bolting on short frame side using four standard mounting

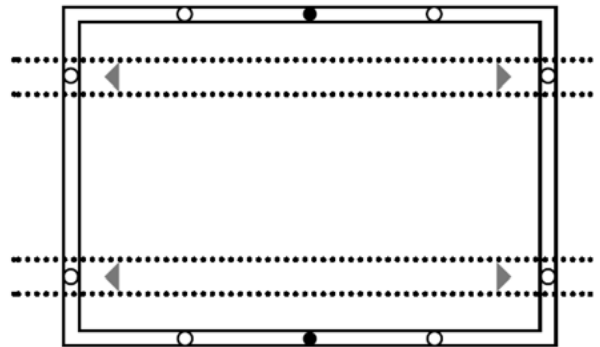

Maximum Load: Uplift load ≤ 2400 Pa
Downforce load ≤ 2400 Pa
Compatible module type:
PEPV-xxx-48, PEPV-xxx-54, PEPV-xxx-60, PEPV-xxx-72,
MEPV-xxx-72, MEPV-xxx-96, MEPV-xxx-60.

Bolting on long frame side using four middle mounting holes. Mounting rails run perpendicularly to the long frame side.

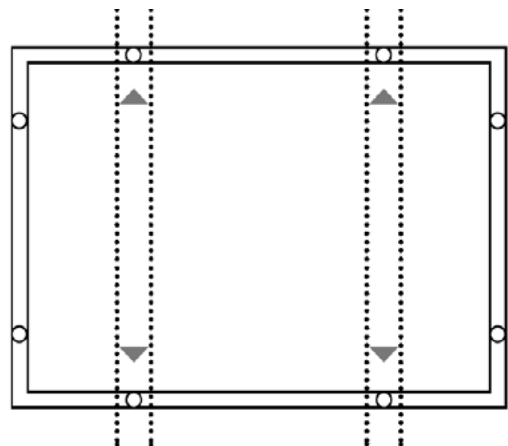

Maximum Load: Uplift load ≤ 2400 Pa
Downforce load ≤ 5400 Pa
Compatible module type:
PEPV-xxx-48, PEPV-xxx-54, PEPV-xxx-60, PEPV-xxx-72,
MEPV-xxx-72, MEPV-xxx-96, MEPV-xxx-60.



Bolting on short frame side using four standard mounting holes. An additional support bar should be placed below the module. Mounting rails should run parallel to the short frame side.

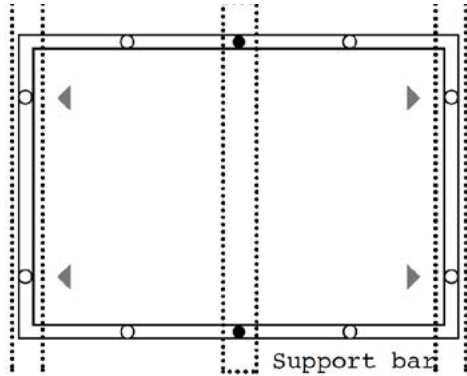

Maximum Load: Uplift load ≤ 2400 Pa
Downforce load ≤ 5400 Pa
Compatible module type:
PEPV-xxx-48, PEPV-xxx-54, PEPV-xxx-60, PEPV-xxx-72,
MEPV-xxx-72, MEPV-xxx-g6, MEPV-xxx-60.

Bolting on long frame side using four innermost mounting holes. Mounting rails run parallel to the long frame side.

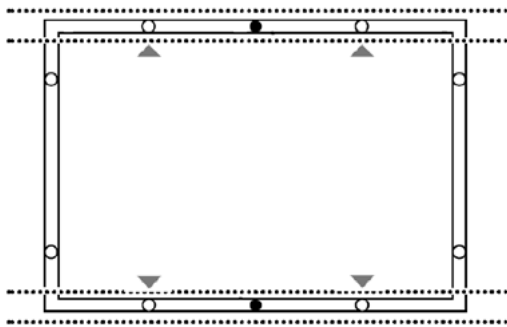

Maximum Load:
Uplift load ≤ 2400 Pa; Downforce load ≤ 4000 Pa
(For PEPV-xxx-48, PEPV-xxx-54, PEPV-xxx-60, PEPV-xxx-72, MEPV-xxx-60, the maximum downforce load can reach up to 5400Pa)
Compatible module type:
PEPV-xxx-48, PEPV-xxx-54, PEPV-xxx-60, PEPV-xxx-72,
MEPV-xxx-72, MEPV-xxx-g6, MEPV-xxx-60.

MOUNTING WITH CLAMPS:

The module clamps should not come into contact with the front glass and must not deform the frame. Be sure to avoid shadowing effects from the module clamps. The module frame is not to be modified under any circumstances. When choosing this type of clamp-mounting method, please be sure to use at least four clamps on each module, two clamps should be attached on each long sides of the module. Depending on the local wind and snow loads, if excessive pressure load is expected, additional clamps or support would be required to ensure the module can bear the load. The applied torque value should be big enough to fix the modules steadily (Please consult with the clamp or support's supplier for the specific torque value). Please find detailed mounting information in the below illustration, the mounting place distance is suggested bigger than C and less than D.

Note: The Movement of the mounting rail and the clamps center line are recommended to be within the black arrow area.

The recommended clamps' length is 50 mm. Failing that, it should never be less than the width of the module's frame.

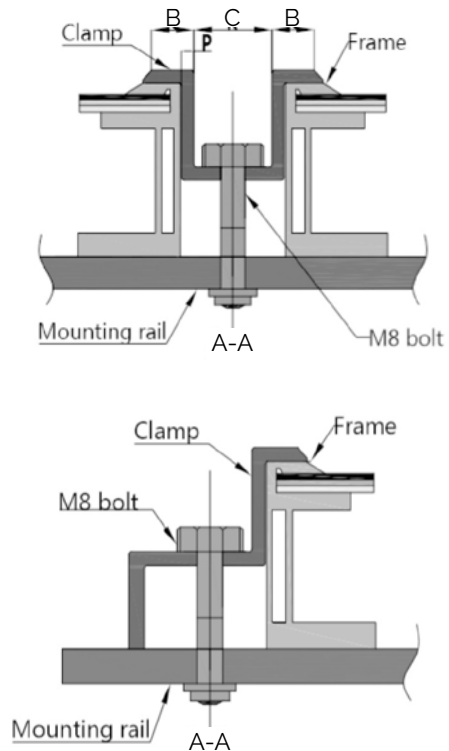



Middle module

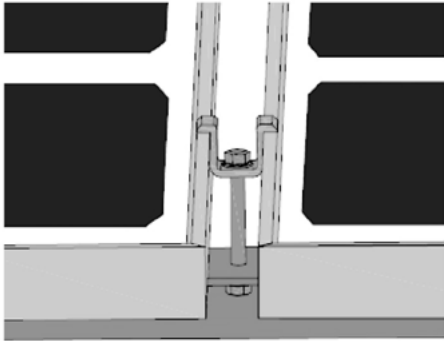

Fringe modules

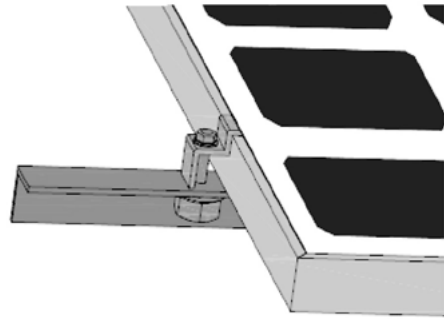

Clamp Mounting on Long Sides of the Frames

The distance from the border of the module to the clamp should be between 22% and 25% of the total module length.

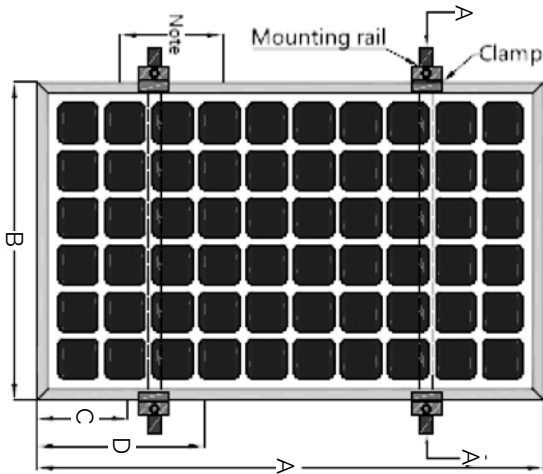

Clamp Mounting on Short Sides of the Frames

The distance from the border of the module to the clamp should be between 12% and 15% of the total module width.

Note: The installation method of clamps on short sides is based on the internal results.

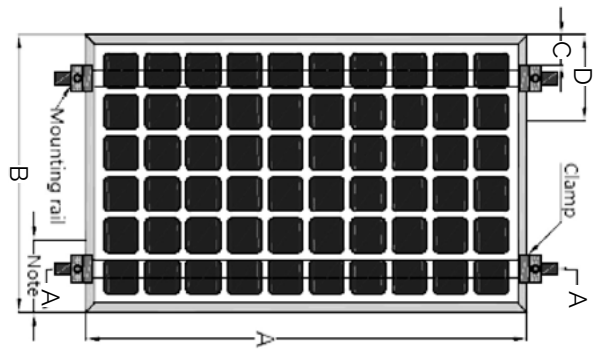



Sales Office:
Colón 1 - 23
46004 Valencia (Spain)

Tel. +34 96 004 55 15
contact@eurenerworld.com

